

# Casting frames and ramps

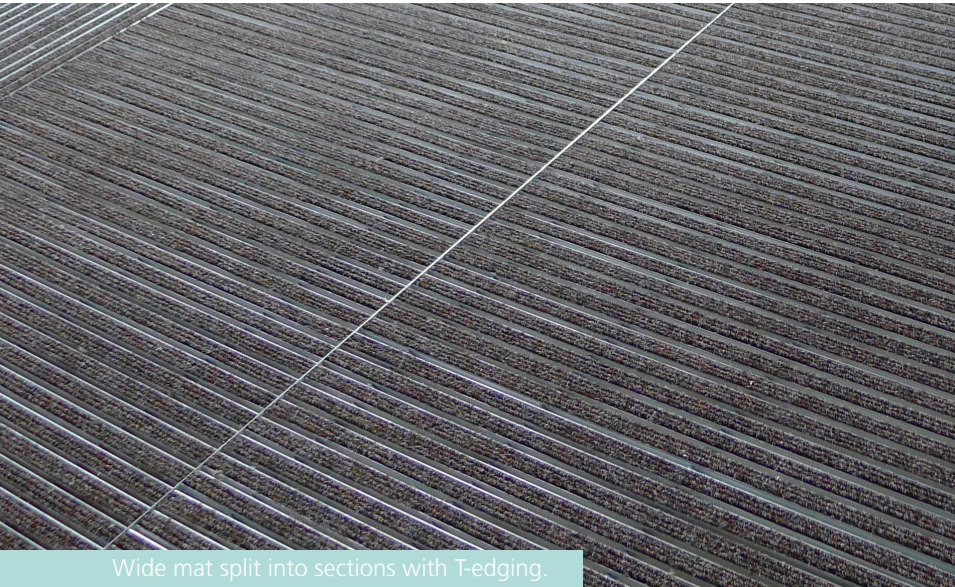

Wide mat split into sections with T-edging.



Ramp edging around a raised outdoor mat.

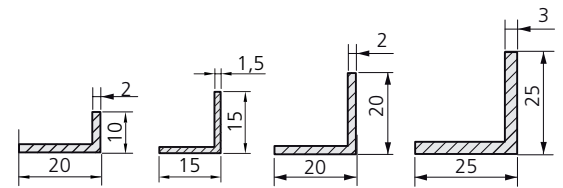
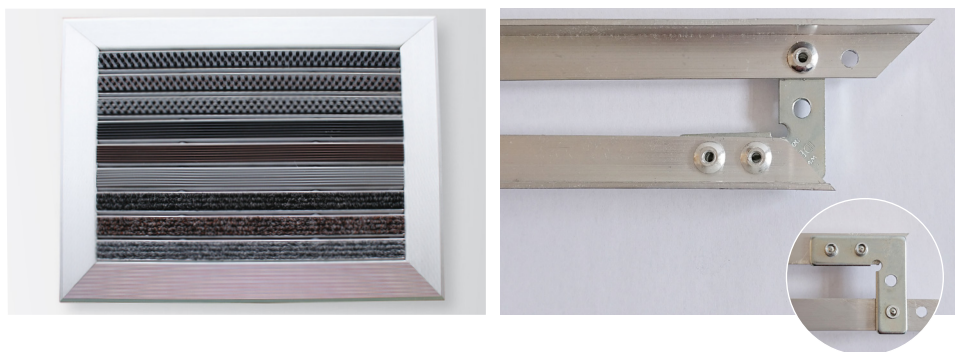

Casting frame for casting into a recess.

**Casting frames** are made from angle sections (L). The accompanying heavy duty corner brackets ensure accurate assembly. The frames have been designed to enable assembly with mitred corners. But they can also be supplied as straight sections in the desired lengths.

**T-edging** is usually used as a separator between two different mats in a single recess.

**Ramp edging** Ideal for mats that are approx. 10-12 mm or 16-20 mm high. The edging is made from aluminium and is used when mats are installed on top of a floor where there are not any recesses. It is attached from above using screws into drilled holes. Edging is supplied without pre-drilled holes, and without screws.

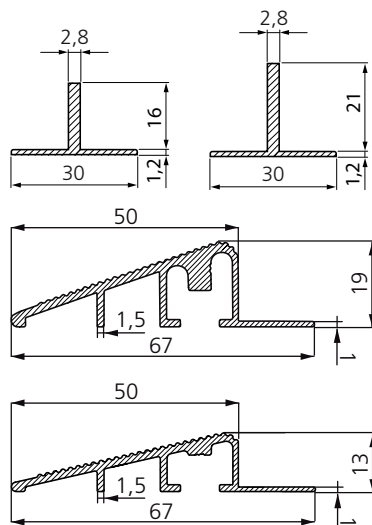

<b>Material:</b>	Aluminium.
<b>Temperature:</b>	-40°C to +70°C
<b>Guarantee:</b>	3 years against manufacturing defects.

Dimensions	Internal dimensions	External dimensions + corner brackets	Article no.
<b>CASTING FRAMES</b>			
20 x 10 (2) mm	8 mm	10 + 7 mm	100/10
15 x 15 (1,5) mm	13,5 mm	15 + 7 mm	100/15
20 x 20 (2) mm	18 mm	20 + 7 mm	100/20
25 x 25 (3) mm	22 mm	25 + 6 mm	100/25
<b>RAMP EDGING</b>			
50 / 67 mm	12 mm		100/12 RAMP
50 / 67 mm	18 mm		100/18 RAMP
<b>T-EDGING</b>			
30 x 17,2 (2,8) mm	16 mm		100/15T
30 x 22,2 (2,8) mm	21 mm		100/20T